

Dockboard Options

Standard

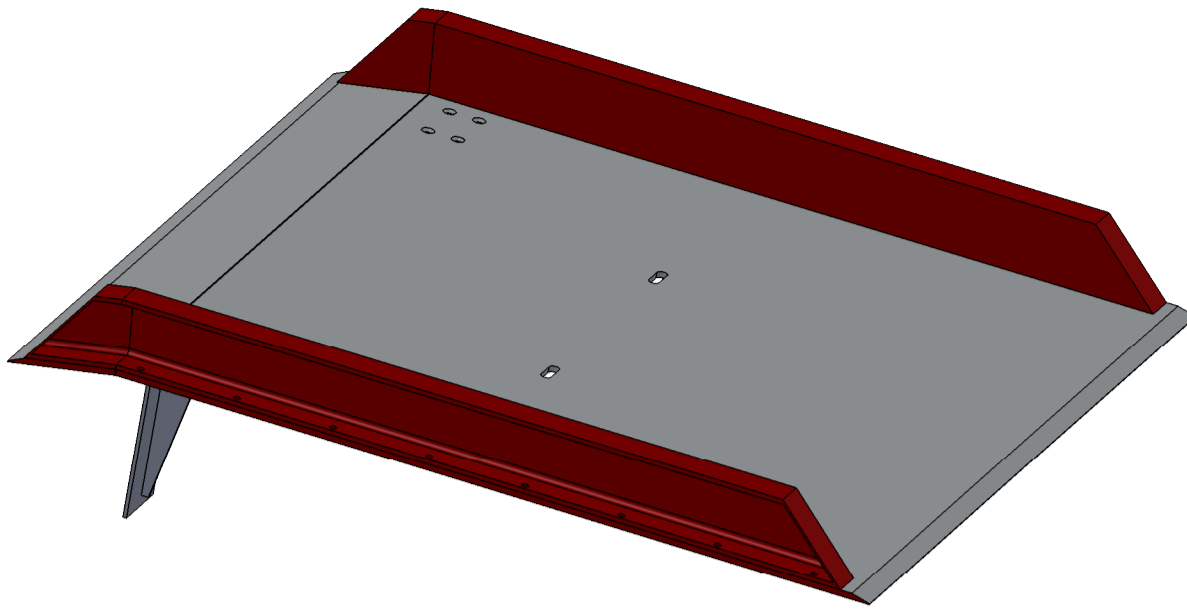

Standard Dockboard features:

- Anti-slip treadplate finish
- Crowned (10°) & bevelled for smooth operation
- One pair of locking legs to prevent movement
- Steel safety side curbs

Fork Truck Lifting Handles (FTH-1)

- Strongly recommended for all Dockboards due to weight

Handle
in stored
position

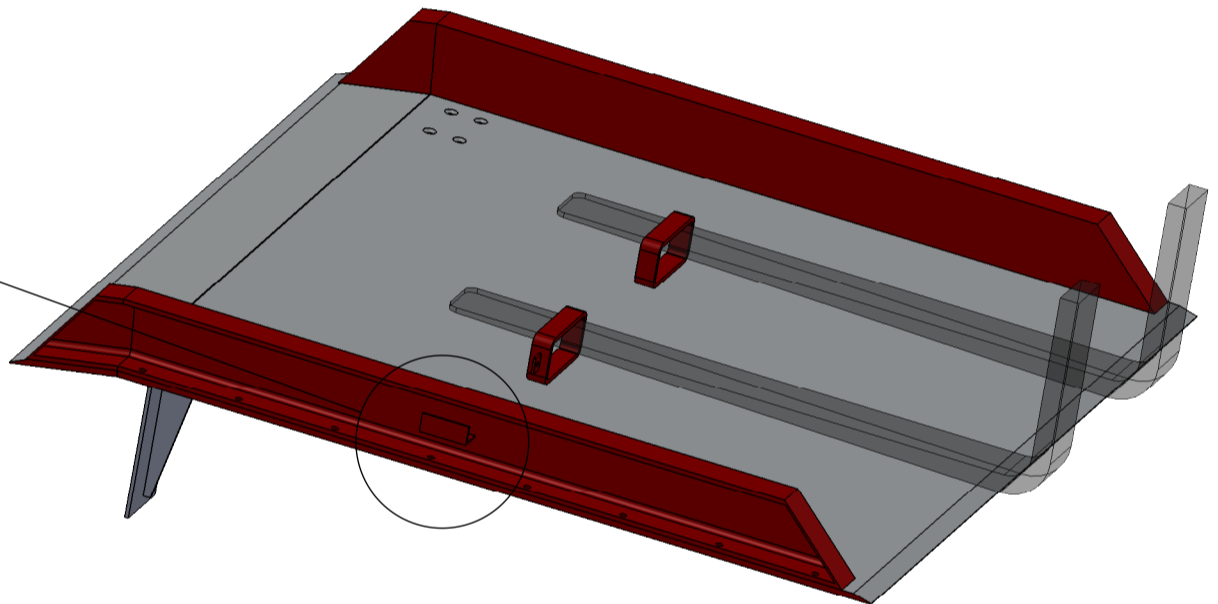
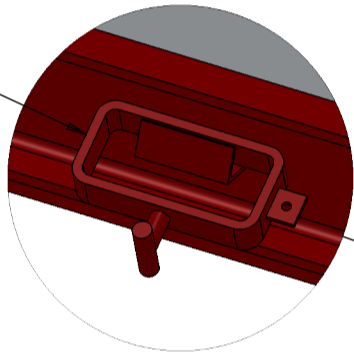

Forktruck Lifting Handles modification features:

- Handles are placed through slots in plate, and rotated 90° for movement with FLT.
- Once the plate is in in position, the handles are stored over the loop type lifting handles.
- Handles secured to plate with chain to prevent seperation/loss.

Note: Securing chains omitted for clarity.

Fixed Span Locking Legs (FSL-1) & Adjustable Span Locking Legs (ASL-1)

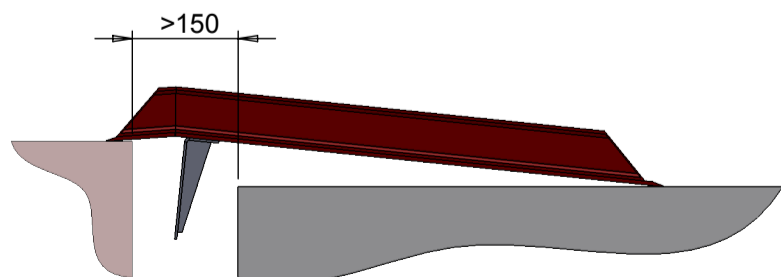
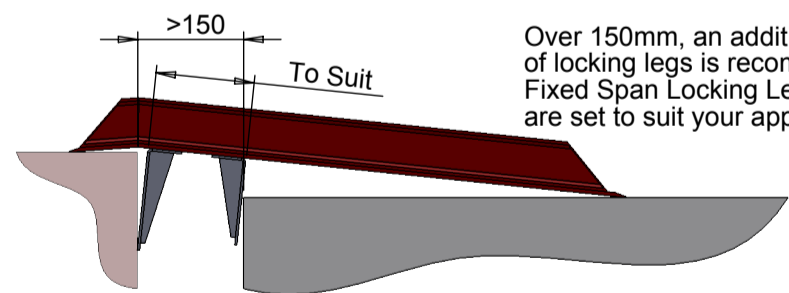
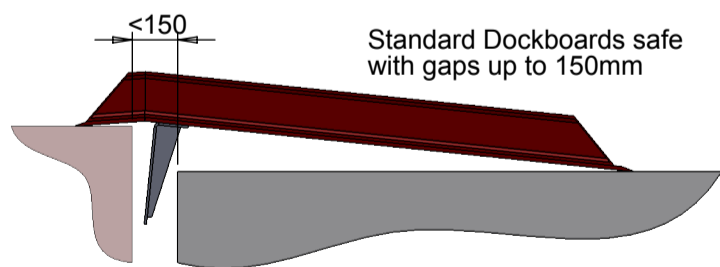

Over 150mm there is a significant risk of the board separating from vehicle - this is not recommended.



Contact us now for assistance selecting the correct equipment for your application.