

PART No: SMY-33-9040-FW-6

Fifteen Tonne Type 6 Mobile Yard ramp. A standard unit with fold down entry ramps, intergrated safety side beams, built in tow bar & manual hydraulic height adjustment for fast & efficient loading operations.

CLASS	SUPER DELUXE		
CAPACITY	15000 Kg		
ESTIMATED LEADTIME	-		
OPTIONAL EXTRAS	Wheel Chocks, Trailer Safety Jack		
HEIGHT DIFFERENTIAL (mm)	MIN POSS.	MAX POSS.	MAX RECOMM.
	890	1680	1250

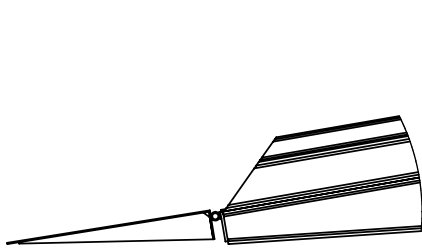
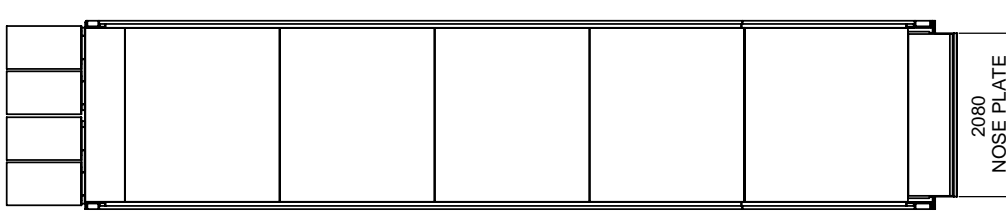
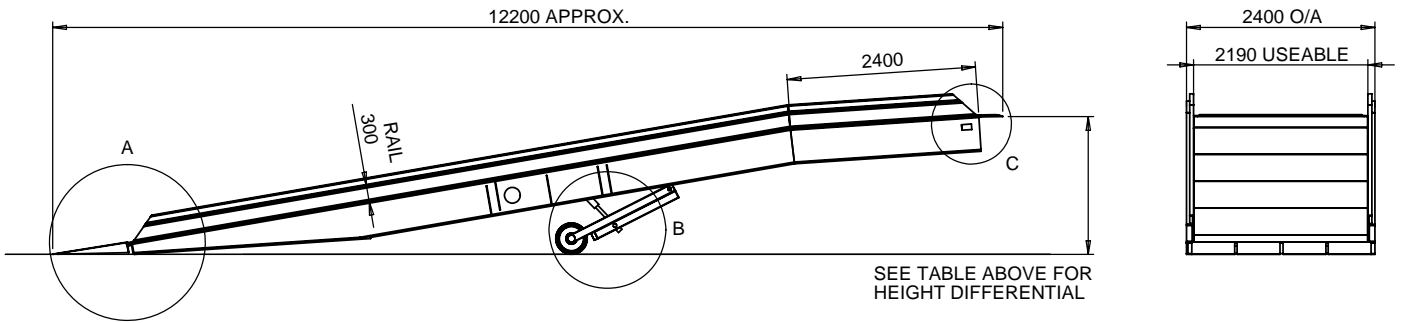
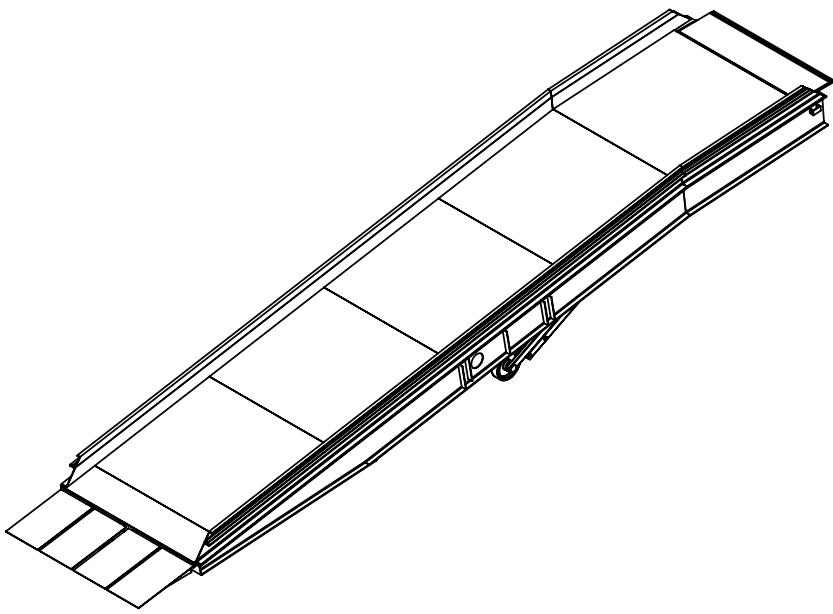

DETAIL A

HINGED ENTRY RAMPS ALLOWING ACCESS TO TOW BAR

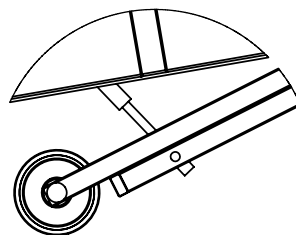

DETAIL B

HYDRAULIC UNDERCARRIAGE FOR FAST AND RELIABLE MANUAL HEIGHT ADJUSTMENT

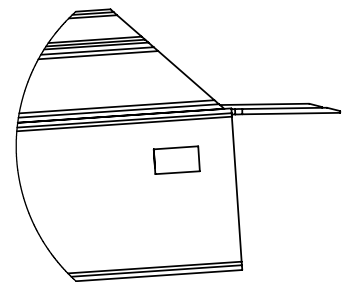

DETAIL C

EXIT LIP AND CHAIN TENSIONING BRACKET FOR SAFE & SECURE LOADING / UNLOADING

All dimensions shown are in millimetres and are intended for reference purposes only; exact product measurements may vary due to applied tolerances and methods of manufacture

